

SPILL AND OVERFILL

The purpose of spill and overfill is to eliminate the chance of a release during fuel deliveries.

Spill protection is an enclosed device “spill bucket” that is installed where the fuel delivery person attaches the hose to the “fill pipe” to dispense fuel into the tank.

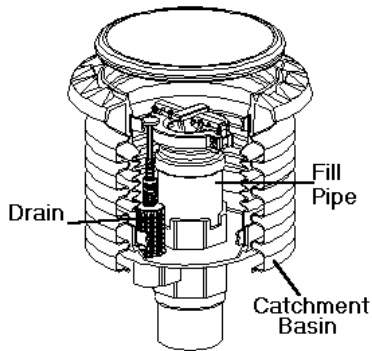

If your UST never receives deliveries of more than 25 gallons at a time, the UST does not need to meet spill prevention requirements. Many used oil tanks fall into this category.

It is designed to catch and hold any drips or spillage that can occur when the delivery hose is detached from the fill pipe after a delivery is made.

Overfill protection is installed inside the fill pipe and/or tank and should stop or reduce the flow of product into the tank or alert the delivery person by audio or visual means before the tank becomes full. It can be any of the following three devices:

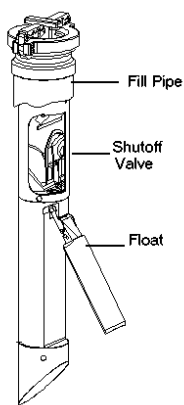

Automatic Shutoff Device

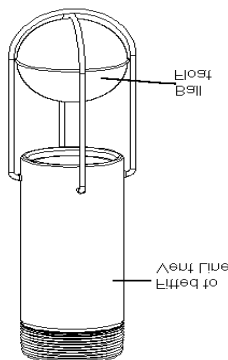

Ball Float Valve

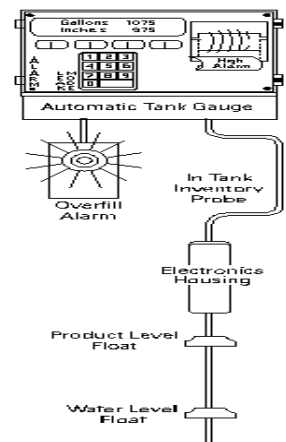

Electronic Overfill Alarm